

# INSTALLATION GUIDE

## UNIGIZER™ SOLAR SYSTEM / SOLAR KIT

with 6, 12 or 18 J Unigizer™ and 135, 190 or 270 W solar panel

### Contents

Starting the installation .....	2
Completing the 135 W installation .....	5
Completing the 190 W installation .....	12
Completing the 270 W installation .....	19
Wiring diagrams .....	26
Components (135 W, 190 W, 270 W) .....	30
Spare parts list .....	36
Maintenance .....	36

This guide explains how to install the following solar systems / kits:

Solar Panel	Unigizer™	Batteries	Total Ah @ 12 V
135 W	6 J	2 x 12 V 72 Ah	144 Ah
	12 J	2 x 6 V 225 Ah	225 Ah
190 W	12 J	2 x 6 V 225 Ah	225 Ah
	18 J	4 x 6 V 225 Ah	450 Ah
270 W	18 J	4 x 6 V 225 Ah	450 Ah

Unigizer™ Solar system = Energizer, battery and solar panel/bits/mounting  
 Unigizer™ Solar kit = Solar panel/bits/mounting.

### Checklist

Carefully unpack your solar system or solar kit. Check that you have all the components (refer to section *Components (135 W, 190 W, 270 W)*, see page 30), and the tools shown below before you start the installation.

- 1 x No. 2 strainer post (2 x posts for a 270 W installation)
- Concrete (or post rammer) for the post installation
- Socket wrench and 13 mm socket
- Hammer
- 18 mm and 10 mm spanners
- 150 mm adjustable spanner
- No. 2 Phillips screwdriver
- Drill and 10 mm drill bit
- Marker pen
- Safety glasses

The solar panel contains glass and is fragile. Handle with care and do not place objects upon it. Clean gently with a soft, damp cloth.

If anything is missing, or if you have any questions about the installation at any time, please contact your dealer or Datamars directly at 0800 878 837.

Some components are heavy and/or large. We recommend that two people work together to make the installation as easy as possible.

### Warnings and other important information

#### WARNING!

- Heavy-duty batteries are supplied. If these batteries are connected incorrectly or shorted, they will produce a large electric current that may be hazardous. We recommend that you consult a qualified electrician if necessary.
- Batteries contain harmful chemicals and when handled incorrectly, may cause injury. Observe the guidelines for battery care, maintenance and safety in this guide and in the documentation supplied.
- The batteries supplied are very heavy. Always use the battery lifting handles supplied in the components to lift the batteries.

Note: We recommend that you wear safety glasses while you are working with the batteries.

© 2016-2023 Datamars Limited

All product names and brand names in this document are trademarks or registered trademarks of their respective holders.

No part of this publication may be photocopied, reproduced, stored in a retrieval system, or transmitted in any form or by any means, electronic, mechanical, photocopying, recording or otherwise without the prior written permission of Datamars Limited. Product specifications may change without prior notice.

For more information on other quality Datamars brands and products, visit [datamars.com](http://datamars.com).

Datamars SA (Global Headquarters)  
 Via Industria 16  
 6814 Lamone  
 Switzerland

**DATAMARS**

For help with this installation in New Zealand or for any other queries about this product, contact us directly at 0800 878 837.

**480 0000-998** (821871) Issue 4 05/2023

## Starting the installation

### Selecting a location for the installation

---

**Caution:**

It is critical to install the solar panel in a north-facing location that is free of shadows all year.

In winter the sun sits very low on the horizon and shadows may be cast by distant objects. Even partial shading from objects such as tree branches will significantly reduce the available output current, and the batteries may not receive sufficient charge.

---

### Preparing the post

---



The solar panel has been designed for mounting onto a wooden fence post with a flat top. A No.2 strainer post is ideal. (If this is not available, use a wooden fence post that has a diameter of 95 - 220 mm and is 2.7 m long or longer.) This is to ensure that the bottom of the solar panel will be approximately 0.5 m above the ground after installation so that long grass will not shadow it from the sun.

At least half of the post needs to be anchored firmly in the ground, so that it will not move in a storm.

If you are installing a new post, we recommend using concrete OR, if the ground is firm, a post rammer.

---

**Note:** If you are installing the 270 W version, you need to prepare two posts. We recommend that you position the posts approximately 2 m apart, on an east-west axis. This means that after the installation is complete, the two solar panels will be side-by-side, facing true north. It is very important that the posts are aligned correctly otherwise one solar panel will cast its shadow onto the other.

---

### Finding true north

---

The highest amount of solar energy will be obtained when the solar panel faces true north.

You will need a compass to help you find true north (not supplied).

---

**Note:** Keep all metal objects and electronic devices away from the compass at all times or the compass may not function correctly.

---

To mark true north on the post:

- 1 Place a compass on top of the post.
- 2 Turn the compass dial until the red needle is aligned with **N** on the compass (this shows magnetic north).
- 3 Turn the compass dial until the red needle shows the approximate amount of magnetic declination at your location (see the map). For example, if you are in the Auckland region turn the compass dial so that the red needle points to approximately 19.5°.
- 4 True north is now shown by **N** on the compass. Use the marker pen to draw a true north arrow, on top of the post, parallel to **N** on the compass. Now you are ready to fit the mounting box to the post.

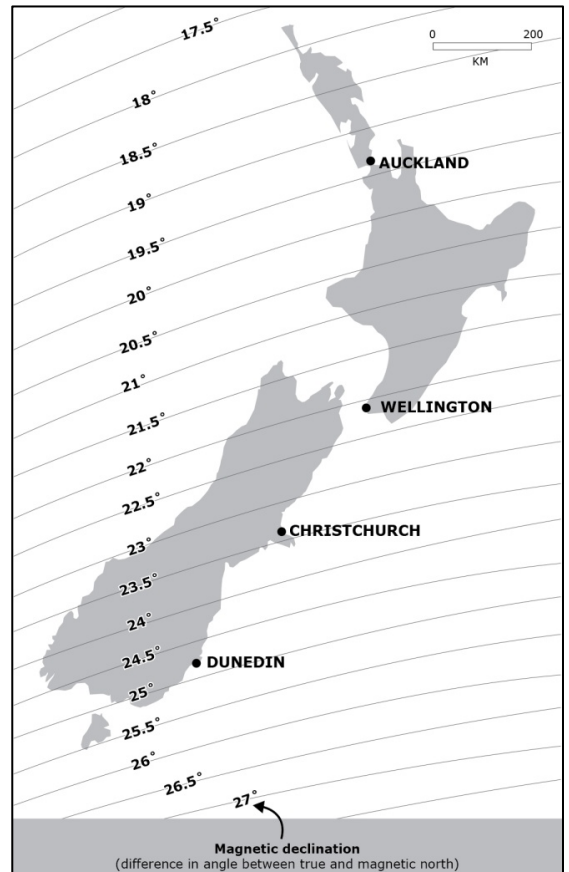

## Fitting the mounting box to the post

### Step 1

Identify the mounting box. (All of the supplied components are identified in the relevant section of this guide.)

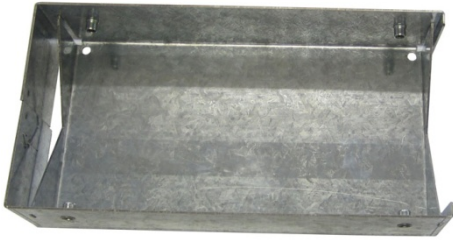

### Step 2

Push the two U-bolts into the corner holes of the mounting box.



### Step 3

Secure the U-bolts loosely at each corner with an M12 flat washer, M12 split washer, and M12 nut.



### Step 4

Slide the mounting box over the post then align it so that both true north arrows are parallel.

Tighten the four nuts until the U-bolts have been sunken into the post slightly. (You may need to hammer the U-bolts through the mounting box in order to achieve this.)



Note: If you are installing the 270 W version, repeat Steps 1-4 on the other post.

## Fixing the side panels to the mounting box

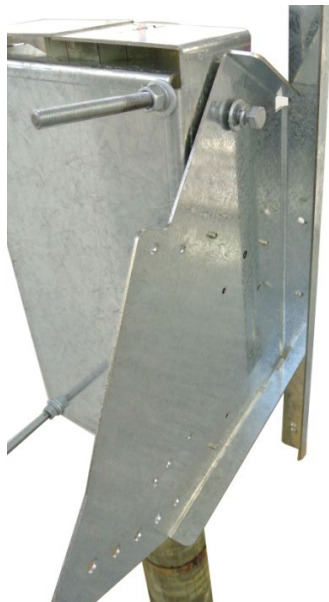

### Step 1

Fit the **right** side panel to the **east** side of the mounting box.

The side panels have different hole configurations, so it is important to mount them correctly, as described here.

Orient the side panel as shown, with the bar facing north and the flanges facing outwards.

Align the top hole in the side panel with the top hole on the mounting box then use an M12x40 bolt, M12 split washer, and an M12 flat washer to loosely attach the side panel.

Do not tighten the bolt yet, as you will need to swing the side panel into its final position later.

### Step 2

Fit the left side panel to the west side of the mounting box as described in Step 1.

Note: If you are installing the 270 W version, repeat Steps 1-2 on the other post.

## Setting the correct tilt angle

### Step 1

The solar panel must be tilted to maximise the solar energy that can be collected during winter. The ideal tilt angle will vary, depending on your location.

As a general rule, the solar panel tilt angle should be set at the angle of latitude for your location PLUS 15°.

The table opposite shows the latitudes and recommended tilt angles for the main centres in New Zealand.

Use the table to find the tilt angle for the main centre closest to your location (e.g. 60° if you are near Dunedin).

Location	Latitude	Tilt angle
Whangarei	36°	51°
Auckland	37°	52°
Wellington	41°	56°
Christchurch	42	57°
Dunedin	45°	60°
Invercargill	46°	61°

### Step 2

There are five holes along the bottom of each side panel. This example shows the holes on the **right** side panel.

Identify which hole to use in order to attach the side panel to the bottom of the mounting box at (or as near as possible to) the recommended tilt angle for your location.

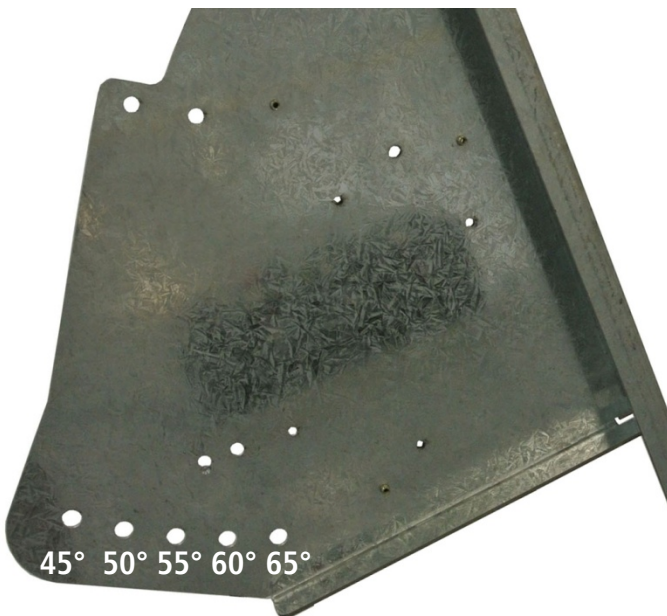

### Step 3

- Use that hole to secure the side panel to the mounting box with an M12x40 bolt, M12 split washer, and an M12 flat washer.
- Tighten the bolt firmly.
- Tighten the bolt at the top of the side panel too.

This example shows the side panel set at a tilt angle of 50°.

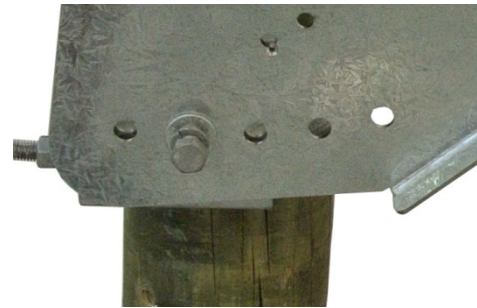

### Step 4

Identify the corresponding hole in the bottom of the left side panel then secure the left side panel to the mounting box in the same way.

Both side panels should now be secured firmly to the mounting box at the recommended tilt angle for your location.

Note: If you are installing the 270 W version, repeat Steps 1-4 on the other post.

You are now ready to complete the installation of the remaining components for your particular solar system or solar kit. Please refer to the relevant section of this guide.



# Completing the 135 W installation

## Preparing the solar panel

This section assumes that you have completed all the steps in the *Starting the installation* section at the beginning of this guide, and have fitted both of the side panels at the correct tilt angle for your location.

### Step 1

Carefully lie the solar panel face down on a clean flat surface (such as the shipping box).

Note: The end of the solar panel that contains the cables must be on the **right-hand side**, when viewed from the back.

Position two rubber washers over the two holes along one long side of the solar panel, as shown.



### Step 2

Position one of the long frame bars over the two rubber washers. Make sure that the flange faces **OUTWARDS** away from the cables.

The holes in the long frame bar should overlie the holes in the rubber washers.



### Step 3

Insert an M8x20 coach bolt from the underside of the solar panel frame, through the rubber washer and hole in the long frame bar.



Place an M8 flat washer and an M8 nut onto the bolt then tighten the nut to secure the long frame bar in place.

Repeat at the other end, so that the long frame bar is secured to the solar panel by the two nuts and bolts.

Repeat Steps 1-3 for the other long side of the solar panel, so that both long frame bars are attached securely to the solar panel.

### Step 4

Lie one of the short frame bars across the back of the solar panel, against the ends of the long frame bars.

The flange should overlie the ends of the long frame bars and the square holes in the frame bars should be aligned, as shown.

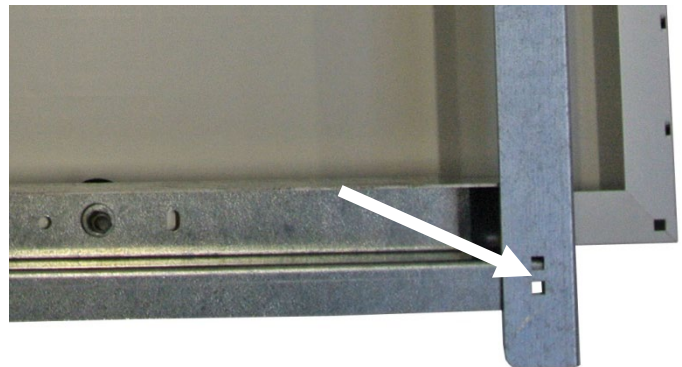

### Step 5

Position a rubber washer and an angle bracket over the square holes at a **bottom corner** of the solar panel (see *Important Note* in Step 1).

Insert an M8x20 coach bolt from the underside of the frame bars, through the square holes, and secure the angle bracket loosely in place with an M8 flat washer and an M8 nut. Do not fully tighten the nut yet as you will need to move the angle bracket into its final position later.

Repeat Steps 4 and 5 for the other short frame bar. Both angle brackets should be in the bottom corners of the solar panel.

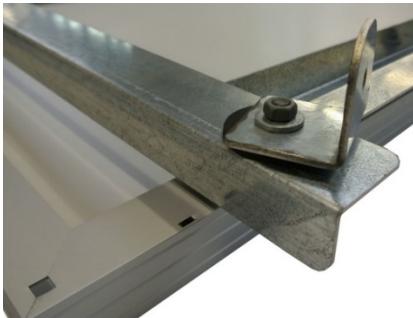

### Step 6

Secure the other ends of the frame bars with M8x20 coach bolts, M8 flat washers, and M8 nuts. Tighten these nuts securely.

Note: There are **NO** rubber washers and angle brackets at the top corners.

Check that your solar panel is assembled correctly, as shown. If so, it is ready to be mounted.



## Mounting the solar panel

### Step 1

Find the small horizontal slots near to the top and bottom of each side panel.

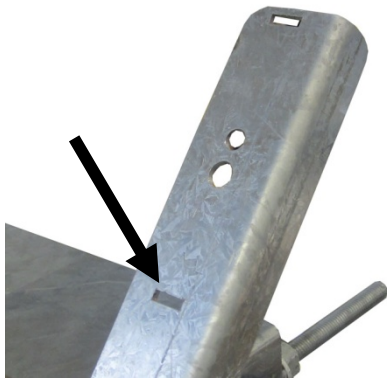

### Step 2

The long frame bars at the top and bottom of the solar panel have small metal tabs.

Lift the solar panel and fit the small metal tabs into the horizontal slots on the side panels.

Note: The end of the solar panel that contains the cables must be on the **right-hand side**, when viewed from the back. (See Step 6 on the previous page.)

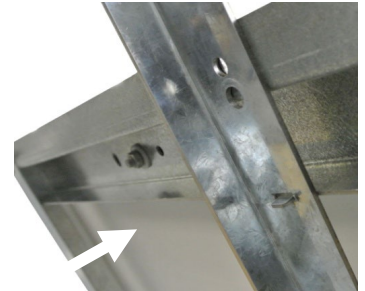

### Step 3

Secure the top of the solar panel frame to the top of one side panel. Insert an M8x20 coach bolt from the underside of the flange, through the corresponding hole in the side panel and secure with an M8 flat washer and an M8 nut.

Repeat at the top of the other side panel.

Attach the bottom of the solar panel frame to the bottom of each side panel using the same method.

You are now ready to attach the post braces to the post.

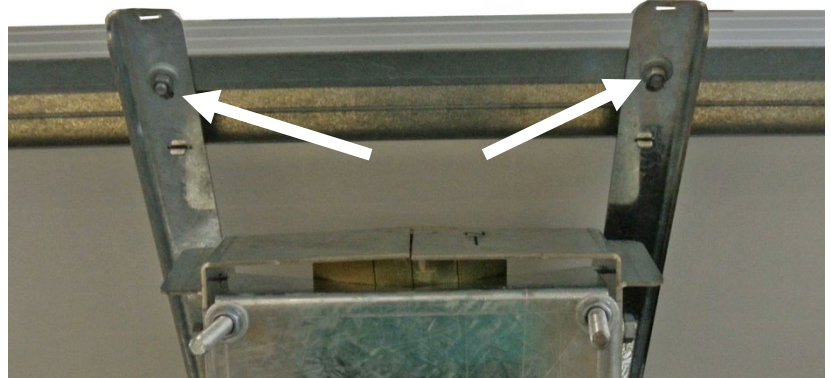

## Attaching the post braces to the post

### Step 1

Loosely attach a post brace to the bottom left angle bracket on the rear of the solar panel, using an M8x20 coach bolt, M8 flat washer, and M8 nut.

Note: Do not tighten the nut yet, as you will need to move the post brace into its final position.



### Step 2

Position the hole in the other end of the post brace against the post and mark this point.

Drill a 10 mm hole in the post where marked, then attach the post brace to the post with an M12x100 coach screw. This photo shows the M12x100 coach screw ready to be screwed into the post.

Tighten the M8 nuts at the angle bracket end.



### Step 3

Attach the other post brace to the bottom right angle bracket, and to the post in the same way.

Note: We recommend positioning one angle bracket slightly higher than the other to avoid the two M12x100 coach screws from hitting each other.

The solar panel should now be attached firmly to both side panels and the post.

This completes the solar panel installation. You are ready to mount and connect the solar regulator control unit.



## Mounting and connecting the solar regulator control unit

### Step 1

Remove the screw at each corner of the solar regulator control unit, then lift off the clear plastic cover. Keep the four screws.



### Step 2

Align the recessed screw hole in each corner of the solar regulator control unit with the four corresponding nutserts (protrusions) in the right side panel.

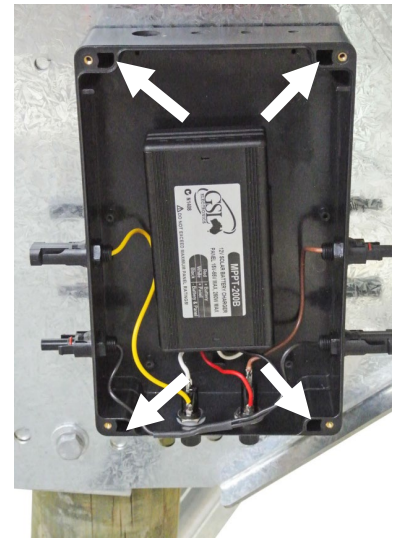

### Step 3

Insert an M4x8 Philips screw into each nutsert.

Tighten each screw to mount the solar regulator control unit securely on the right side panel.

Screw the cover back into place using the four screws from Step 1.



### Step 4

On the left side of the solar regulator control unit, connect:

- the **+** lead from the solar panel to the **+ SOLAR PANEL INPUT**
- the **-** lead from the solar panel to the **- SOLAR PANEL INPUT**.



### Step 5

Find the splitter (shown below). All the cables are labelled for easy installation. Identify the **C+** cable and the **D-** cable.

Note: Leave the cable support between cables **E-**, **F-**, **G+**, and **H+** in place.



### Step 6

On the right side of the solar regulator control unit, connect:

- the splitter **C+** cable to the **C+ CONTROLLER OUTPUT**
- the splitter **D-** cable to the **D- CONTROLLER OUTPUT**.

This completes the installation of the solar regulator control unit. You are ready to mount and connect the Unigizer™.





## Mounting and connecting the Unigizer™

Note: If you purchased a solar system, the Unigizer™ is included. If you purchased a solar kit, you need to supply a Unigizer™ in order to complete the installation.

### Step 1

Connect the Unigizer™ loom **H+** cable to the splitter **H+** cable.

Connect the Unigizer™ loom **F-** cable to the splitter **F-** cable.



### Step 2

The left side panel contains a choice of five nutserts to accommodate different types of Unigizers.

If you are using a 6 J Unigizer™, match the mounting keyhole slots on the rear with two of the nutserts at the top. If you are using a 12 J Unigizer™, match the mounting keyhole slots on the rear with two of the nutserts at the top and one nutsert at the bottom (as shown in this example).

Insert an M6x12 Philips screw into each of your chosen nutserts and tighten until about 5 mm of each screw protrudes.

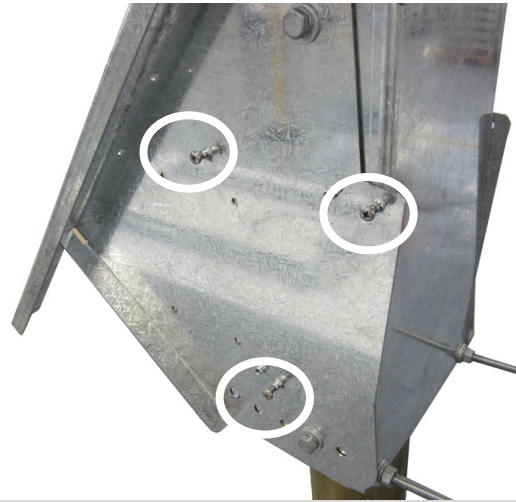

### Step 3

Route the Unigizer™ loom between the post and the solar panel so that it does not hang down loosely behind the post.

Make sure that the Unigizer™ is turned OFF.

Plug the Unigizer™ loom into the power socket on the rear of the Unigizer™, as shown.



### Step 4

Lift the Unigizer™ and slide the mounting keyhole slots over the screws on the side panel, then push it down to secure in place.

Check that the Unigizer™ is mounted securely; if not, remove it and adjust the screws. This completes the Unigizer™ installation.

You are ready to connect the battery option that is supplied (144 Ah or 225 Ah). See one of the following two sections.





## Connecting the 144 Ah battery option to the splitter

### Notes:

A wiring diagram is included at the end of this guide.

Refer to the *Warnings and other important information* section at the beginning of this guide before you connect the batteries.

### Step 1

Find the **G+** cable. This has a fuse holder and ring terminal at one end, and a connector labelled **G+** at the other end.



### Step 2

Find the **E-** cable. This has a ring terminal at one end and a connector labelled **E-** at the other end.



### Step 3

Connect the **E-** connector to the splitter **E-** cable. Connect the **G+** connector to the splitter **G+** cable.



### Step 4

Position the battery box within easy reach of the cables then remove the lid. If necessary, put both of the batteries into the box using the yellow lifting handles, as shown.

Note: Orient the batteries so that both **negative** terminals are on the same side of the battery box.



### Step 5

Find the **BATTERY--** cable.



### Step 6

Place one ring terminal of the negative (**BATTERY--**) cable over the Battery 2 **negative** terminal.

Place the supplied washer on top of the ring terminal, and fasten with the supplied nut.



### Step 7

Insert the ring terminal of the **E-** cable through the hole in the battery box that is closest to the **negative** terminal of the other battery (Battery 1).

Place the **E-** ring terminal AND the other ring terminal of the negative (**BATTERY--**) cable over the Battery 1 **negative** terminal. Place the supplied washer on top of the two ring terminals, and fasten with the supplied nut.



### Step 8

This photo shows the two negative terminals connected together with the **BATTERY--** cable, and the **E-** cable connected to the negative terminal of Battery 2.

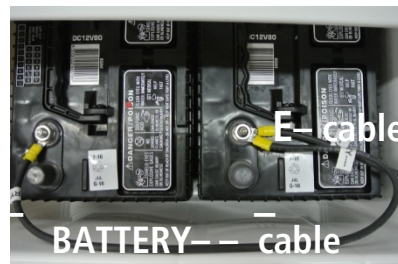

Step 8 continued

Find the fuse holder cable.

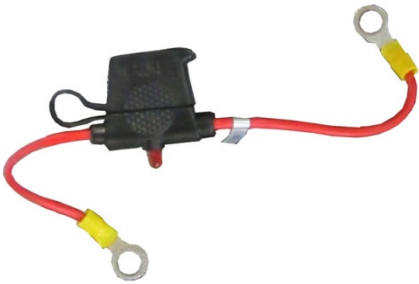

Place one ring terminal of the fuse holder cable over the Battery 1 **positive** terminal.

Place the supplied washer on top of the ring terminal, and fasten with the supplied nut.

Step 9

Insert the ring terminal of the **G+** cable through the hole in the battery box that is closest to the **positive** terminal of Battery 2.

Place the **G+** ring terminal AND the other ring terminal of the fuse holder cable over Battery 2 **positive** terminal.

Place the supplied washer on top of the ring terminal, and fasten with the supplied nut.



Step 10

Insert a 20 A blade fuse into each of the fuse holders. (The red light glows ONLY if the fuse is blown.)

Tidy all cables with cable ties as necessary. Coil and stow any spare cable inside the battery box, if desired, then replace the battery box lid.

This completes the ENTIRE installation.

Turn ON the Unigizer™. If the Unigizer™ does not power ON, check through these installation instructions again and/or refer to the guide supplied with your Unigizer™.

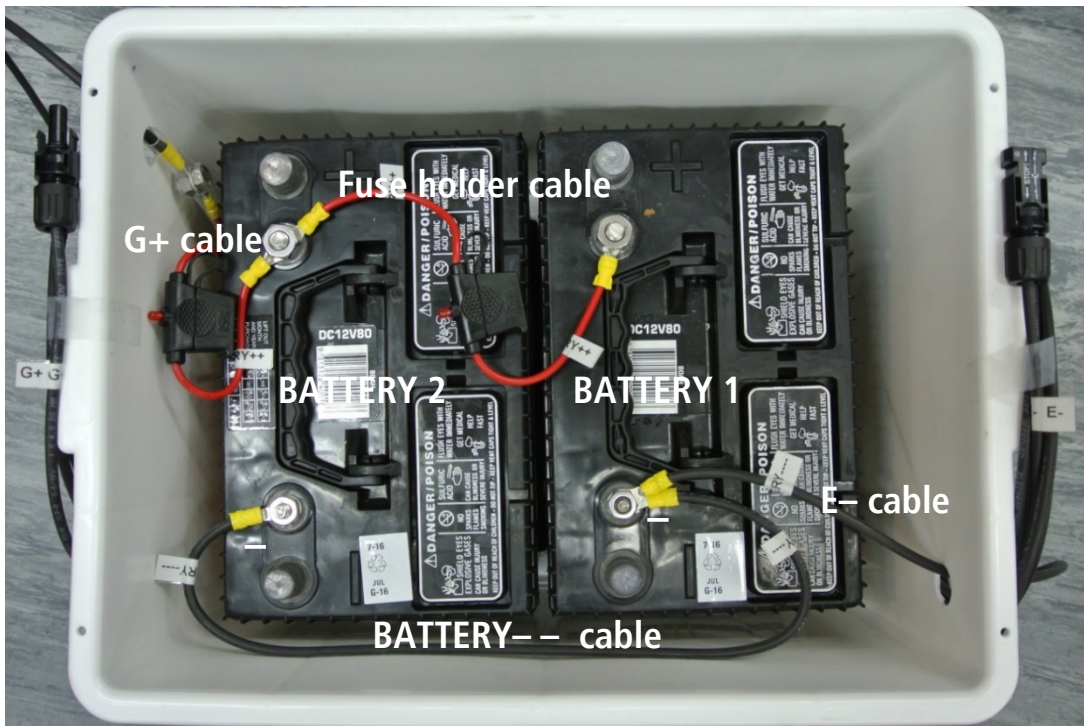

Note: Now that the entire installation is complete, we recommend that you fence off the area to protect the components from damage.

## Connecting the 225 Ah battery option to the splitter

A wiring diagram is included at the end of this guide.

Refer to the *Warnings and other important information* section at the beginning of this guide before you connect the batteries.

### Step 1

Find the **E-** cable. This has a ring terminal labelled **BATTERY--** and a connector labelled **E-**.

Find the **G+** cable. This has a ring terminal labelled **BATTERY++** and a connector labelled **G+**.



### Step 2

Connect the **E-** connector to the splitter **E-** cable.

Connect the **G+** connector to the splitter **G+** cable.



### Step 3

Position the battery box within easy reach of the cables then remove the lid.

If necessary, put both of the 6 V batteries into the box using the yellow lifting handles, as shown.



### Step 4

Find the fuse holder cable.

Use the two ring terminals on the fuse holder cable to connect the **positive** terminal of one 6 V battery to the **negative** terminal of the other 6 V battery so that they will function as a single 12 V battery.



Note: Orient the batteries so that both **negative** terminals are on the same side of the battery box.

Secure each ring terminal with the nut supplied on each battery terminal.

### Step 5

Insert the **G+** ring terminal through the hole in the battery box that is closest to the **positive** terminal. Secure the ring terminal on the positive terminal with the nut.

Insert the **E-** ring terminal through the other hole in the battery box. Secure the ring terminal on the **negative** terminal with the nut.

Insert the 20 A fuse into the fuse holder. (The red light glows **ONLY** if the fuse is blown.)

Tidy all cables with cable ties as necessary. Coil and stow any spare cable inside the battery box, if desired. Replace the battery box lid.

This completes the **ENTIRE** installation.

Turn **ON** the Unigizer™. If the Unigizer™ does not power **ON**, check through these installation instructions again and/or refer to the guide supplied with your Unigizer™.

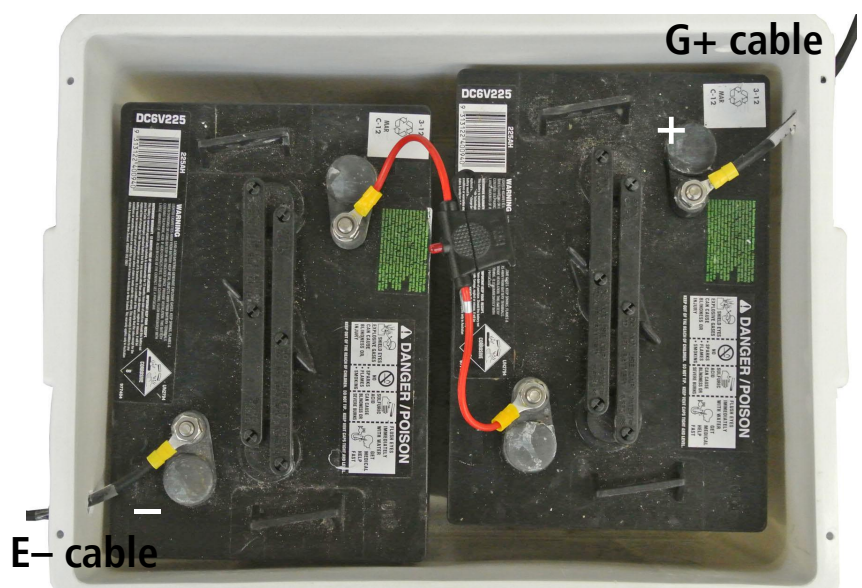

Note: Now that the entire installation is complete, we recommend that you fence off the area to protect the components from damage.



## Completing the 190 W installation

### Preparing the solar panel

This section assumes that you have completed all the steps in the *Starting the installation* section at the beginning of this guide, and have fitted both of the side panels at the correct tilt angle for your location.

#### Step 1

Carefully lie the solar panel face down on a clean flat surface (such as the shipping box).

Note: The end of the solar panel that contains the cables must be on the **right-hand side**, when viewed from the back.

Position two rubber washers over the two holes along one long side of the solar panel, as shown.

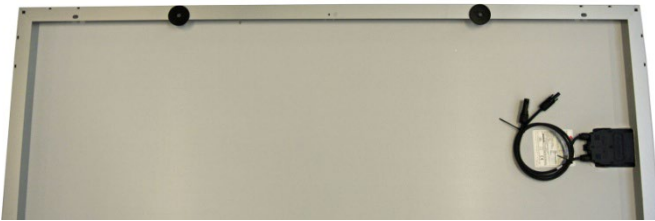

#### Step 2

Position one of the long frame bars over the two rubber washers. Make sure that the flange faces **INWARDS** towards the cables.

The holes in the long frame bar should overlie the holes in the rubber washers.

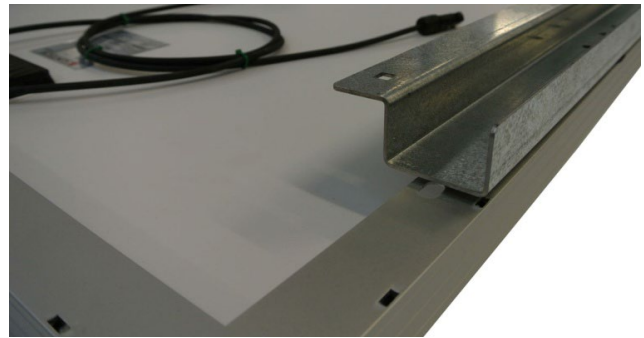

#### Step 3

Insert an M8x20 coach bolt from the underside of the solar panel frame, through the rubber washer and hole in the long frame bar.

Place an M8 flat washer and an M8 nut onto the bolt then tighten the nut to secure the long frame bar in place.



Repeat at the other end, so that the long frame bar is secured to the solar panel by the two nuts and bolts.

Repeat Steps 1-3 for the other long side of the solar panel, so that both long frame bars are attached securely to the solar panel.



#### Step 4

Lie one of the short frame bars across the back of the solar panel, against the ends of the long frame bars.

The flange should overlie the ends of the long frame bars and the square holes in the frame bars should be aligned, as shown.

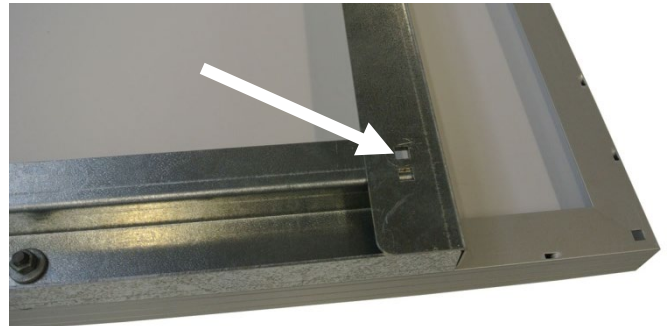

#### Step 5

Position a rubber washer and an angle bracket over the square holes at a **bottom corner** of the solar panel (see the *Important Note* in Step 1).

Insert an M8x20 coach bolt from the underside of the frame bars, through the square holes, and secure the angle bracket loosely in place with an M8 flat washer and an M8 nut. Do not tighten the nut yet.

Repeat Steps 4 and 5 for the other short frame bar. The two angle brackets should be in the bottom corners of the solar panel.



#### Step 6

Secure the other ends of the frame bars with M8x20 coach bolts, M8 flat washers, and M8 nuts. Tighten these nuts securely.

Note: There are **NO** rubber washers and angle brackets at the top corners.

Check that your solar panel is assembled correctly, as shown. If so, it is ready to be mounted.

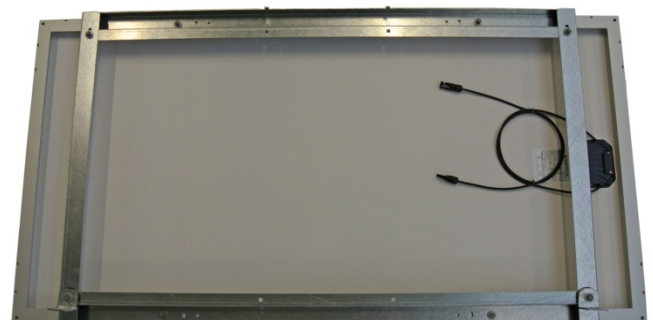

## Mounting the solar panel

### Step 1

Find the small horizontal slot at the top and bottom of each side panel.

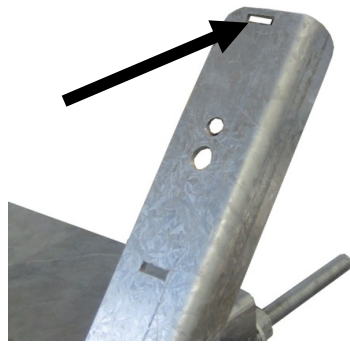

### Step 2

The long frame bars at the top and bottom of the solar panel have small metal tabs.

Lift the solar panel and fit the small metal tabs into the horizontal slots on the side panels.

Note: The end of the solar panel that contains the cables must be on the **right-hand side**, when viewed from the back. (See Step 6 on the previous page.)

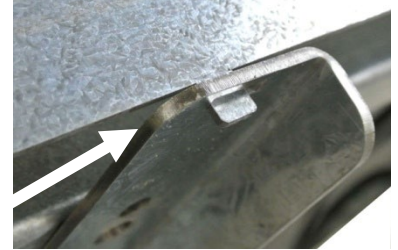

### Step 3

Attach the top of the solar panel securely to the top of one side panel. Insert an M8x20 coach bolt from the underside of the flange, through the corresponding hole in the side panel and secure with an M8 flat washer and an M8 nut.

Repeat at the top of the other side panel.

Attach the bottom of the solar panel to the bottom of each side panel using the same method.

You are now ready to attach the post braces to the post.

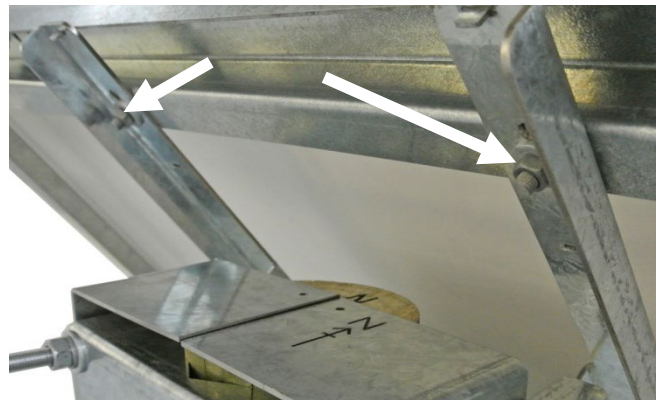

## Attaching the post braces to the post

### Step 1

Loosely attach a post brace to the bottom left angle bracket on the rear of the solar panel, using an M8x20 coach bolt, M8 flat washer, and an M8 nut.

Note: Do not tighten the nut yet, as you will need to move the post brace into its final position.

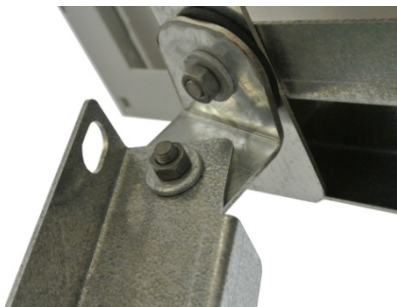

### Step 2

Position the hole in the other end of the post brace against the post and mark this point.

Drill a 10 mm hole in the post where marked, then attach the post brace to the post with an M12x100 coach screw. This picture shows the M12x100 coach screw ready to be screwed into the post.

Tighten the M8 nuts at the angle bracket end.



### Step 3

Attach the other post brace to the bottom right-angle bracket and to the post in the same way.

Note: We recommend positioning one angle bracket slightly higher than the other to avoid the two M12x100 coach screws from hitting each other.

The solar panel should now be attached firmly to both side panels and the post.

**This completes the solar panel installation. You are ready to mount and connect the solar regulator control unit.**



## Mounting and connecting the solar regulator control unit

### Step 1

Remove the screw at each corner of the solar regulator control unit, then lift off the clear plastic cover. Keep the four screws.



### Step 2

Align the recessed screw hole in each corner of the solar regulator control unit with the four corresponding nutserts (protrusions) in the right side panel.

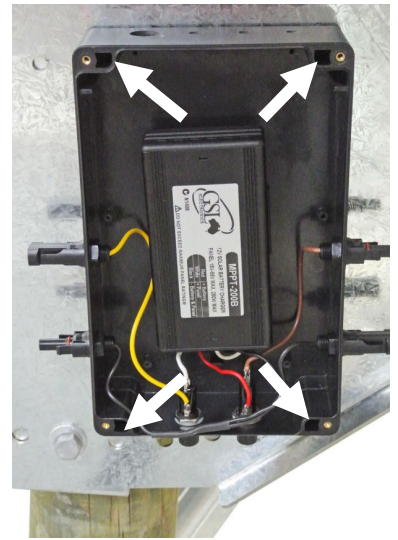

### Step 3

Insert an M4x8 Philips screw into each nutsert.

Tighten each screw to mount the solar regulator control unit securely on the right side panel.

Screw the cover back into place using the four screws from Step 1.



### Step 4

On the left side of the solar regulator control unit, connect:

- the **+** lead from the solar panel to the **+ SOLAR PANEL INPUT**
- the **-** lead from the solar panel to the **- SOLAR PANEL INPUT**.



### Step 5

Find the splitter (shown below). All the cables are labelled for easy installation. Identify the **C+** cable and the **D-** cable.

Note: Leave the cable support between cables **E-**, **F-**, **G+**, and **H+** in place.



### Step 6

On the right side of the solar regulator control unit, connect:

- the splitter **C+** cable to the **C+ CONTROLLER OUTPUT**
- the splitter **D-** cable to the **D- CONTROLLER OUTPUT**.

This completes the installation of the solar regulator control unit. You are ready to mount and connect the Unigizer™.





## Mounting and connecting the Unigizer™

Note: If you purchased a solar system, the Unigizer™ is included. If you purchased a solar kit, you need to supply a Unigizer™ in order to complete the installation.

### Step 1

Connect the Unigizer™ loom **H+** cable to the splitter **H+** cable.

Connect the Unigizer™ loom **F-** cable to the splitter **F-** cable.



### Step 2

The left side panel contains a choice of five nutserts to accommodate different types of Unigizers.

Match the mounting keyhole slots on the rear of your 12 J or 18 J Unigizer™ housing with two nutserts at the top and one nutsert at the bottom.

Insert an M6x12 Philips screw into each of your chosen nutserts and tighten until about 5 mm of each screw protrudes, as shown.

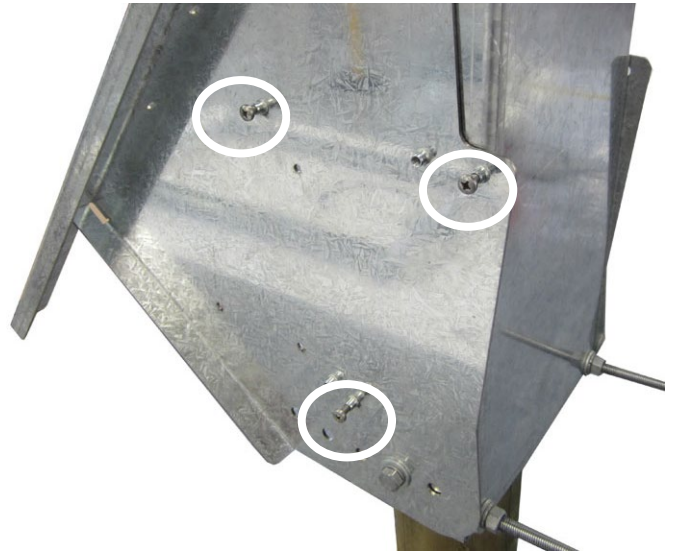

### Step 3

Route the Unigizer™ loom between the post and the solar panel so that it does not hang down loosely behind the post.

Make sure that the Unigizer™ is turned OFF.

Plug the Unigizer™ loom into the power socket on the rear of the Unigizer, as shown.



### Step 4

Lift the Unigizer™ and slide the mounting keyhole slots over the screws on the side panel, then push it down to secure in place.

Check that the Unigizer™ is mounted securely; if not, remove it and adjust the screws. This completes the Unigizer™ installation.

You are ready to connect the battery option that is supplied (225 Ah or 450 Ah). See one of the following two sections.



## Connecting the 225 Ah battery option to the splitter

A wiring diagram is included at the end of this guide.

Refer to the *Warnings and other important information* section at the beginning of this guide before you connect the batteries.

### Step 1

Find the **E-** cable. This has a ring terminal labelled **BATTERY--** and a connector labelled **E-**.

Find the **G+** cable. This has a ring terminal labelled **BATTERY++** and a connector labelled **G+**.



### Step 2

Connect the **E-** connector to the splitter **E-** cable.

Connect the **G+** connector to the splitter **G+** cable.



### Step 3

Position the battery box within easy reach of the cables then remove the lid.

If necessary, put both of the 6 V batteries into the box using the yellow lifting handles, as shown.

Note: Orient the batteries so that both **negative** terminals are on the same side of the battery box.



### Step 4

Find the fuse holder cable.

Use the two ring terminals on the fuse holder cable to connect the **positive** terminal of one 6 V battery to the **negative** terminal of the other 6 V battery so that they will function as a single 12 V battery.

Secure each ring terminal with the nut supplied on each battery terminal.

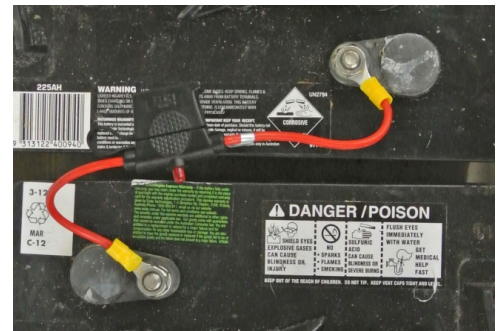

### Step 5

Insert the **G+** ring terminal through the hole in the battery box that is closest to the **positive** terminal. Secure the ring terminal on the positive terminal with the nut.

Insert the **E-** ring terminal through the other hole in the battery box. Secure the ring terminal on the **negative** terminal with the nut.

Insert the 20 A fuse into the fuse holder. (The red light glows ONLY if the fuse is blown.)

Tidy all cables with cable ties as necessary. Coil and stow any spare cable inside the battery box, if desired. Replace the battery box lid.

This completes the ENTIRE installation.

Turn ON the Unigizer™. If the Unigizer™ does not power ON, check through these installation instructions again and/or refer to the guide supplied with your Unigizer™.

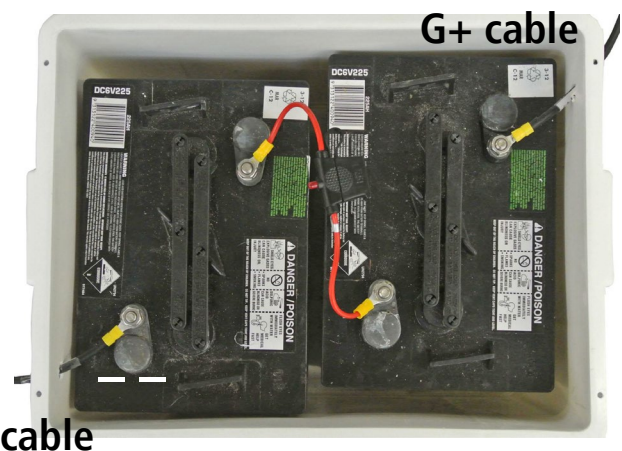

Note: Now that the entire installation is complete, we recommend that you fence off the area to protect the components from damage.

## Connecting the 450 Ah battery option to the splitter

A wiring diagram is included at the end of this guide.

Refer to the *Warnings and other important information* section at the beginning of this guide before you connect the batteries.

### Step 1

Find the cable that has a ring terminal labelled **BATTERY--** and a connector labelled **E-**.

Find the cable that has a ring terminal labelled **BATTERY++** and a connector labelled **G+**. Each cable is clearly labelled.



### Step 2

Connect the **E-** connector to the splitter **E-** cable.

Connect the **G+** connector to the splitter **G+** cable.



### Step 3

Position both battery boxes within easy reach of each other and the cables.

Remove the lids from both battery boxes.

If necessary, put two batteries into one battery box using the yellow lifting handles, as shown, then repeat for the other battery box.

Note: Orient the batteries so that both **negative** terminals are on the same side of the battery box.



### Step 4

Find a fuse holder cable.

Use the two ring terminals on the fuse holder cable to connect the **positive** terminal of one 6 V battery to the **negative** terminal of the other 6 V battery so that they will function as a single 12 V battery.

Secure each ring terminal with the nut supplied on each battery terminal.

Repeat this step for the other battery box.



### Step 5

Find the two **J+** battery connection cables and the two **K-** battery connection cables. Each cable is labelled clearly.

Insert one **J+** ring terminal through the hole in the battery box that is closest to the **positive** terminal. Secure the ring terminal onto the **positive** terminal with the nut.

Insert one **K-** ring terminal through the other hole in the **same battery box**. Secure the ring terminal onto the **negative** terminal with the nut.

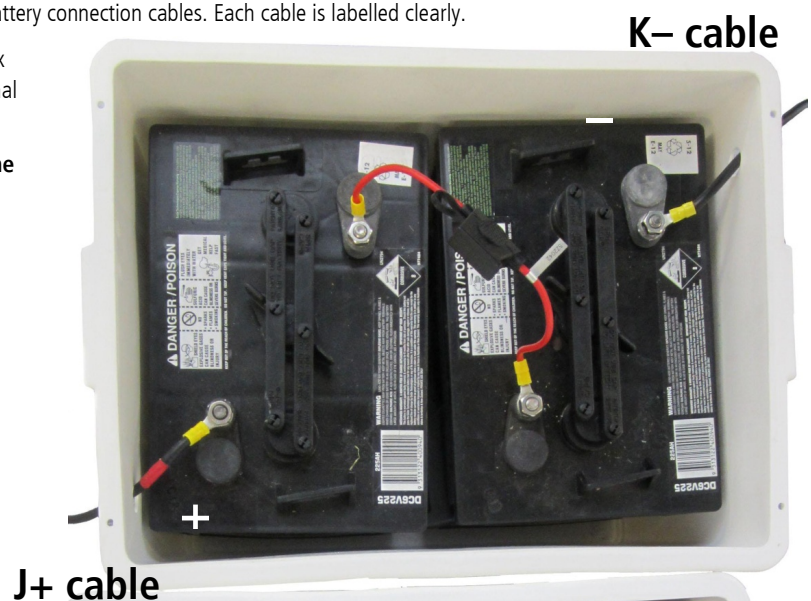



**Step 6**

At the **other battery box**, insert the other **J+** ring terminal AND the **G+** ring terminal through the hole that is closest to the **positive** terminal.

Connect both ring terminals to the **positive** terminal and secure with the nut.

Insert the other **K-** ring terminal AND the **E-** ring terminal through the other hole.

Connect both ring terminals to the **negative** terminal and secure with the nut.

Insert a 20 A fuse into each fuse holder. (The red light glows **ONLY** if the fuse is blown.)

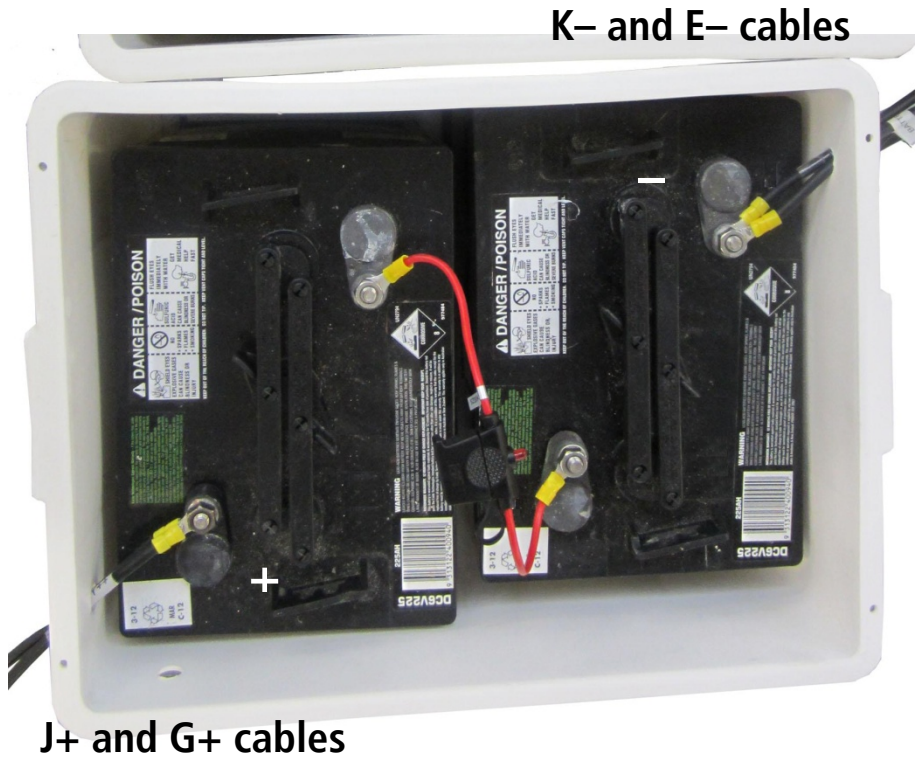

**Step 7**

Connect the two **J+** cable ends together to form one continuous **J+** cable.

Connect the two **K-** cable ends to form one continuous **K-** cable.



**Step 8**

Tidy all cables with cable ties as necessary. Coil and stow any spare cable inside the battery boxes, if desired.

Replace the lids of both battery boxes.

This completes the ENTIRE installation.

Turn ON the Unigizer™. If the Unigizer™ does not power ON, check through these installation instructions again and/or refer to the guide supplied with your Unigizer™.

Note: Now that the entire installation is complete, we recommend that you fence off the area to protect the components from damage.

# Completing the 270 W installation

## Preparing the solar panels

This section assumes that you have completed all the steps in the *Starting the installation* section at the beginning of this guide, and have fitted the side panels to both posts at the correct tilt angle for your location.

### Step 1

Carefully lie one solar panel face down on a clean flat surface (such as the shipping box).

Note: The end of the solar panel that contains the cables must be on the **right-hand side**, when viewed from the back.

Position two rubber washers over the two holes along one long side of the solar panel, as shown.



### Step 3

Insert an M8x20 coach bolt from the underside of the solar panel frame, through the rubber washer and hole in the long frame bar.



Place an M8 flat washer and an M8 nut onto the bolt then tighten the nut to secure the long frame bar in place.

Repeat at the other end, so that the long frame bar is secured to the solar panel by the two nuts and bolts.

Repeat Steps 1-3 for the other long side of the solar panel, so that both long frame bars are attached securely to the solar panel.

### Step 5

Position a rubber washer and an angle bracket over the square holes at a **bottom corner** of the solar panel (see *Important Note* in Step 1).

Insert an M8x20 coach bolt from the underside of the frame bars, through the square holes, and secure the angle bracket loosely in place with an M8 flat washer and an M8 nut. Do not fully tighten the nut yet as you will need to move the angle bracket into its final position later.

Repeat Steps 4 and 5 for the other short frame bar. Both angle brackets should be in the bottom corners of the solar panel.

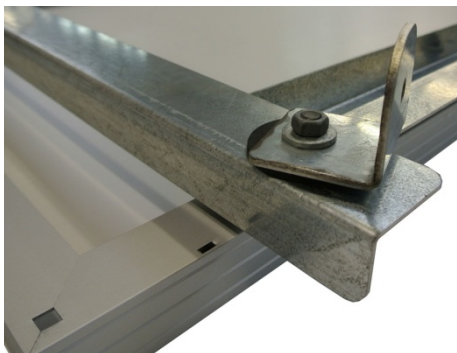

### Step 2

Position one of the long frame bars over the two rubber washers. Make sure that the flange faces **OUTWARDS** away from the cables.

The holes in the long frame bar should overlie the holes in the rubber washers.



### Step 4

Lie one of the short frame bars across the back of the solar panel, against the ends of the long frame bars.

The flange should overlie the ends of the long frame bars and the square holes in the frame bars should be aligned, as shown.

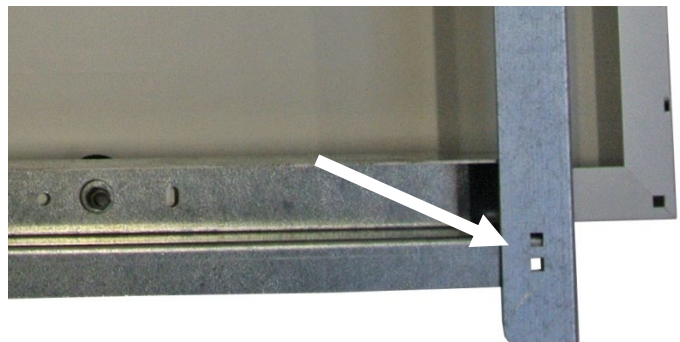

### Step 6

Secure the other ends of the frame bars with M8x20 coach bolts, M8 flat washers, and M8 nuts. Tighten these nuts securely.

Note: There are **NO** rubber washers and angle brackets at the top corners.

Check that your solar panel is assembled correctly, as shown. If so, repeat Steps 1-6 for the other solar panel. Both solar panels are ready to be mounted.



## Mounting the solar panel

### Step 1

Find the small horizontal slots near the top and bottom of each side panel.



### Step 2

The long frame bars at the top and bottom of the solar panel have small metal tabs.

Lift the solar panel and fit the small metal tabs into the horizontal slots on the side panels.

Note: The end of the solar panel that contains the cables must be on the **right-hand side**, when viewed from the back. (See Step 6 on the previous page.)



### Step 3

Secure the top of the solar panel to one side panel. Insert an M8x20 coach bolt from the underside of the flange, through the corresponding hole in the side panel and secure with an M8 flat washer and an M8 nut.

Repeat at the top of the other side panel.

Attach the bottom of the solar panel to the bottom of each side panel using the same method.

Repeat Steps 1-3 for the other solar panel.

You are now ready to attach the post braces to the posts.



## Attaching the post braces to the post

### Step 1

Loosely attach a post brace to the bottom left angle bracket on the rear of the solar panel, using an M8x20 coach bolt, M8 flat washer, and an M8 nut.

Note: Do not tighten the nut yet, as you will need to move the post brace into its final position.



### Step 2

Position the hole in the other end of the post brace against the post and mark this point.

Drill a 10 mm hole in the post where marked, then attach the post brace to the post with an M12x100 coach screw. This picture shows the M12x100 coach screw ready to be screwed into the post.

Tighten the M8 nuts at the angle bracket end.



### Step 3

Attach the other post brace to the bottom right angle bracket and the post in the same way.

Note: We recommend positioning one angle bracket slightly higher than the other to avoid the two M12x100 coach screws from hitting each other.

The solar panel should now be attached firmly to both side panels and the post.

Repeat Steps 1-3 for the other solar panel. This completes the installation of both solar panels. You are ready to mount and connect the solar regulator control units.





## Mounting and connecting the solar regulator control units

### Step 1

Remove the screw at each corner of one control unit, then lift off the clear plastic cover.

Keep the four screws.



### Step 2

Align the recessed screw hole in each corner of the solar regulator control unit with the four corresponding nutserts (protrusions) in one of the right side panels.

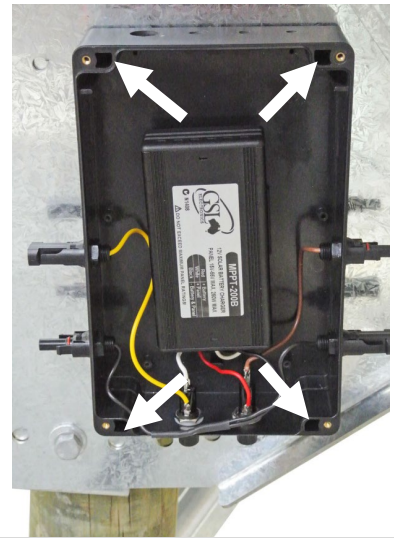

### Step 3

Insert an M4x8 Philips screw into each nutsert.

Tighten each screw to mount the solar regulator control unit securely on this right side panel.

Screw the cover back into place using the four screws from Step 1.



### Step 4

On the left side of this solar regulator control unit, connect:

- the **+** lead from this solar panel to the **+ SOLAR PANEL INPUT**
- the **-** lead from this solar panel to the **- SOLAR PANEL INPUT**.



### Step 5

Find a splitter (shown below). All the cables in the splitters are labelled for easy installation. Identify the **C+** cable and the **D-** cable on this splitter.

Note: Leave the cable support between cables **E-**, **F-**, **G+**, and **H+** in place.



### Step 6

On the right side of this solar regulator control unit, connect the splitter **C+** cable to the **C+ CONTROLLER OUTPUT** then connect the splitter **D-** cable to the **D- CONTROLLER OUTPUT**.

This completes the installation of one solar regulator control unit. Repeat Steps 1-6 to install the other solar regulator control unit on the other right side panel. You are ready to mount and connect the Unigizer™.



## Mounting and connecting the Unigizer™

Note: If you purchased a solar system, the Unigizer™ is included. If you purchased a solar kit, you need to supply a Unigizer™ in order to complete the installation.

### Step 1

We recommend that you install the Unigizer™ on the left side panel of the **left-hand** solar panel, as viewed from the rear. This provides you with more working space during the rest of the installation.

Connect the Unigizer™ loom **H+** cable to the splitter **H+** cable.

Connect the Unigizer™ loom **F-** cable to the splitter **F-** cable.



### Step 2

The left side panel contains a choice of five nutserts to accommodate different types of Unigizers.

Match the mounting keyhole slots on the rear of your 18 J Unigizer™ housing with two nutserts at the top and one at the bottom.

Insert an M6x12 Philips screw into each of your chosen nutserts and tighten until about 5 mm of each screw protrudes, as shown.

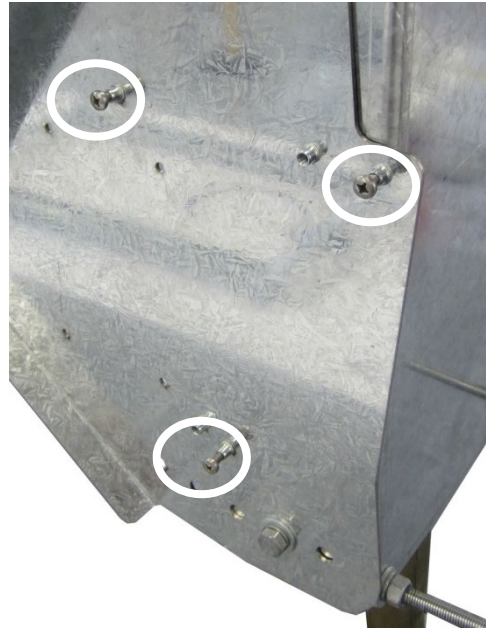

### Step 3

Route the Unigizer™ loom between this post and the solar panel so that it does not hang down loosely behind the post.

Make sure that the Unigizer™ is turned OFF.

Plug the Unigizer™ loom into the power socket on the rear of the Unigizer, as shown.



### Step 4

Lift the Unigizer™ and slide the mounting keyhole slots over the screws on the side panel, then push it down to secure in place.

Check that the Unigizer™ is mounted securely; if not, remove it and adjust the screws.

This completes the Unigizer™ installation. You are ready to connect the 450 Ah battery.



## Connecting the 450 Ah battery to the splitters

A wiring diagram is included at the end of this guide.

Refer to the *Warnings and other important information* section at the beginning of this guide before you connect the batteries.

### Step 1

Position both battery boxes behind and between the two solar panels, within easy reach of the cables.

Remove the lids from both of the battery boxes.

If necessary, put two batteries into one battery box using the yellow lifting handles, then repeat for the other battery box.

Note: Orient the batteries so that both **negative** terminals are on the same side of the battery box.



### Step 2

Find a fuse holder cable.

Use the two ring terminals on the fuse holder cable to connect the **positive** terminal of one 6 V battery to the **negative** terminal of the other 6 V battery so that they will function as a single 12 V battery.

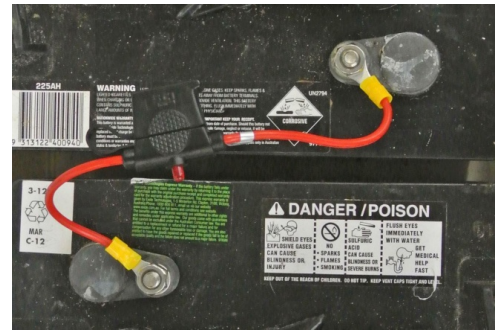

Secure each ring terminal with the nut supplied on each battery terminal. Repeat this step for the other battery box.

### Step 3

Find a cable that has a ring terminal labelled **BATTERY--** and a connector labelled **E-**.



### Step 4

Find a cable that has a ring terminal labelled **BATTERY++** and a connector labelled **G+**.



### Step 5

Working on the **right-hand** solar panel, as viewed from the rear, connect the splitter **E-** cable to the **E-** connector then connect the splitter **G+** cable to the **G+** connector.

The **F-** and **H+** connectors on this splitter are not used. These two connectors are weatherproof and do not need any protective shielding.



### Step 6

Repeat Steps 3-4. Working on the **left-hand** solar panel, as viewed from the rear, connect the splitter **E-** cable to the **E-** connector then connect the splitter **G+** cable to the **G+** connector.

You already connected the **F-** and **H+** connectors on this splitter when you installed the Unigizer™ (see Step 1 on the previous page).





Step 7

Find the two **J+** battery connection cables. Find the two **K-** battery connection cables.

Working on the **right-hand** battery box, as viewed from the rear of the installation, insert the **BATTERY-** ring terminal AND one **K-** ring terminal through the hole in the battery box that is closest to the **negative** terminal of one battery.

Connect both ring terminals to the negative terminal and secure with the nut.

Working on the **same battery box**, insert the **BATTERY++** ring terminal AND one **J+** ring terminal through the hole in the battery box that is closest to the **positive** terminal of the other battery.

Connect both ring terminals to the positive terminal and secure with the nut.

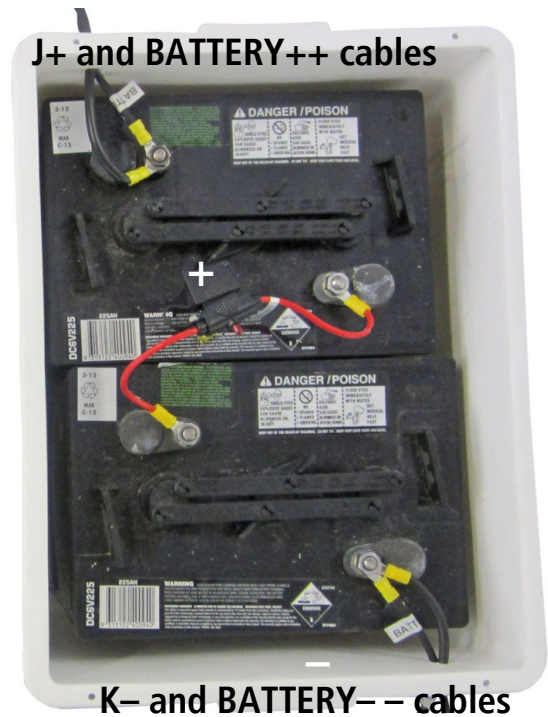

**K- and BATTERY-- cables**

Step 8

Working on the **left-hand** battery box, as viewed from the rear of the installation, insert the other **J+** ring terminal AND the other **BATTERY++** ring terminal through the hole in the battery box that is closest to the **positive** terminal of one battery.

Connect both ring terminals to the **positive** terminal, secure with the nut.

Working on the **same battery box**, insert the other **BATTERY-** ring terminal AND the other **K-** ring terminal through the hole in the battery box that is closest to the **negative** terminal of the other battery.

Connect both ring terminals to the **negative** terminal, secure with the nut.

Insert a 20 A fuse into each fuse holder. (The red light glows ONLY if the fuse is blown.)



**J+ and BATTERY++ cables**

Continued...

**Step 9**

Connect the two **J+** cable ends to form one continuous **J+** cable.  
 Connect the two **K-** cable ends to form one continuous **K-** cable.



**Step 10**

Tidy all cables with cable ties as necessary. Coil and stow any spare cable inside the battery boxes, if desired.

Replace the lids of both battery boxes.

This completes the ENTIRE installation.

Turn ON the Unigizer™. If the Unigizer™ does not power ON, check through these installation instructions again and/or refer to the guide supplied with your Unigizer™.

Note: Now that the entire installation is complete, we recommend that you fence off the area to protect the components from damage.

**Overview of the battery connections**

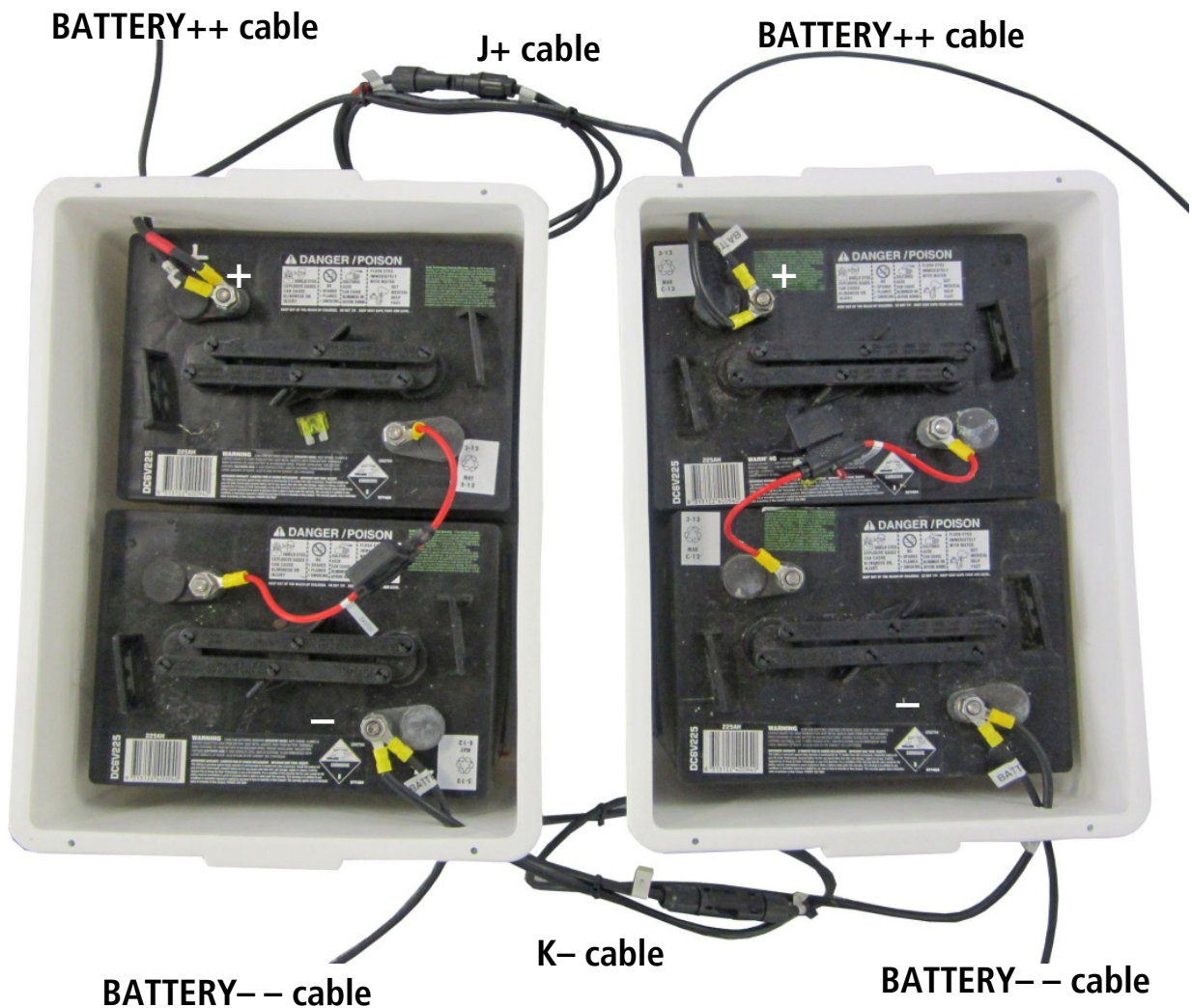

# Wiring diagrams

144 Ah wiring for 135 W 6 J installations

---

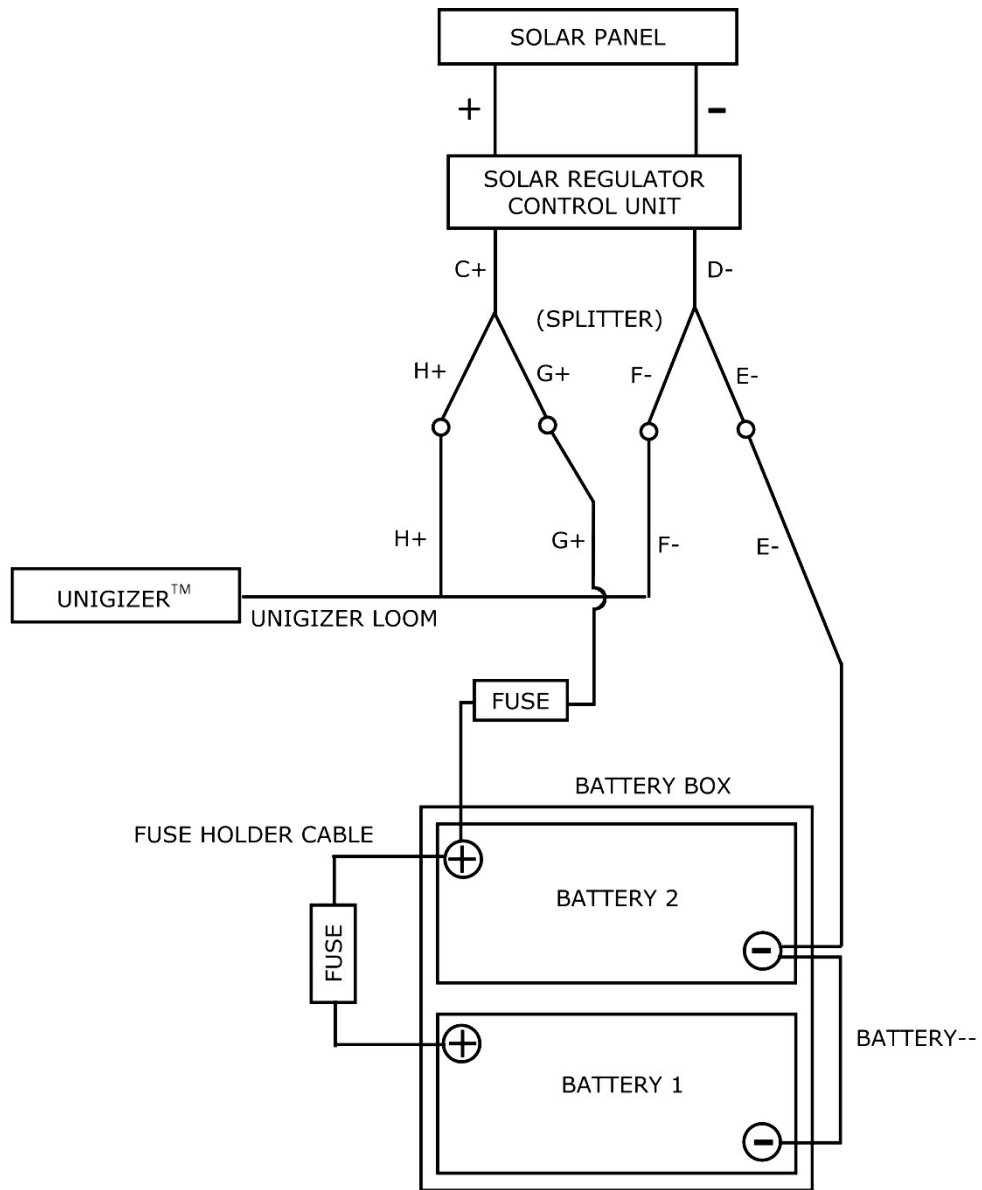



225 Ah wiring for 135 W 12 J and 190 W 12 J installations

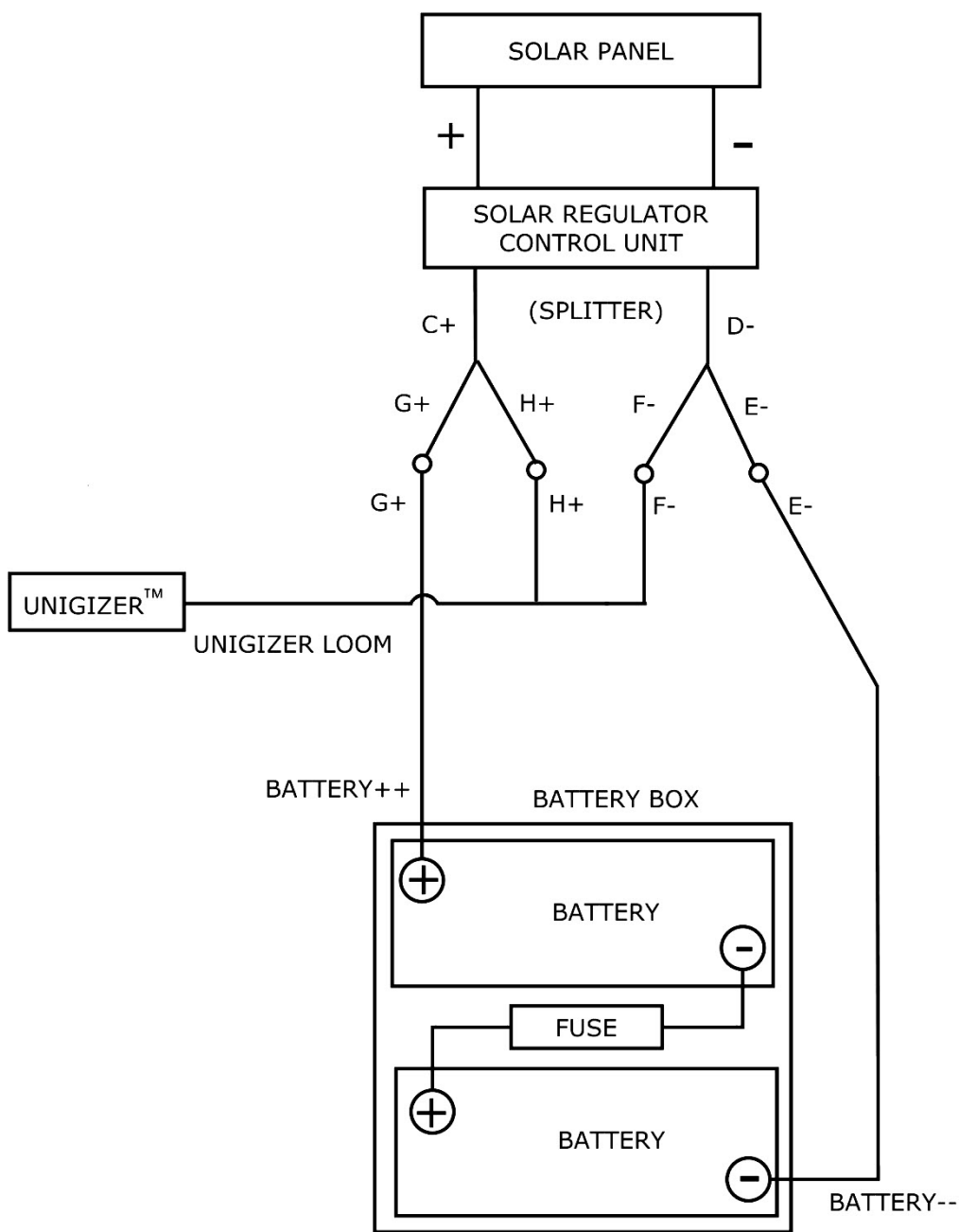

450 Ah wiring for 190 W 18 J installations

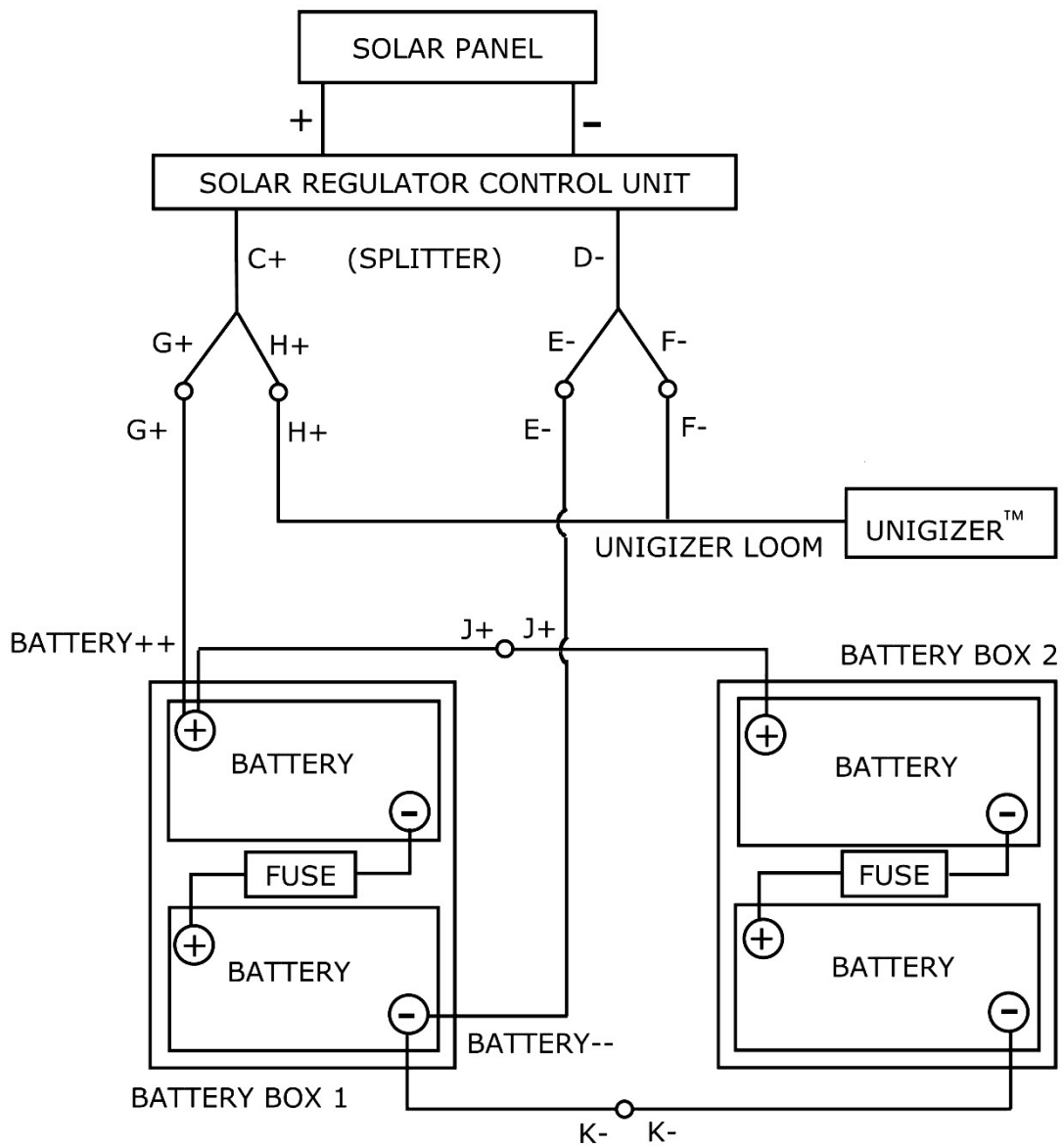

450 Ah wiring for 270 W 18 J installations

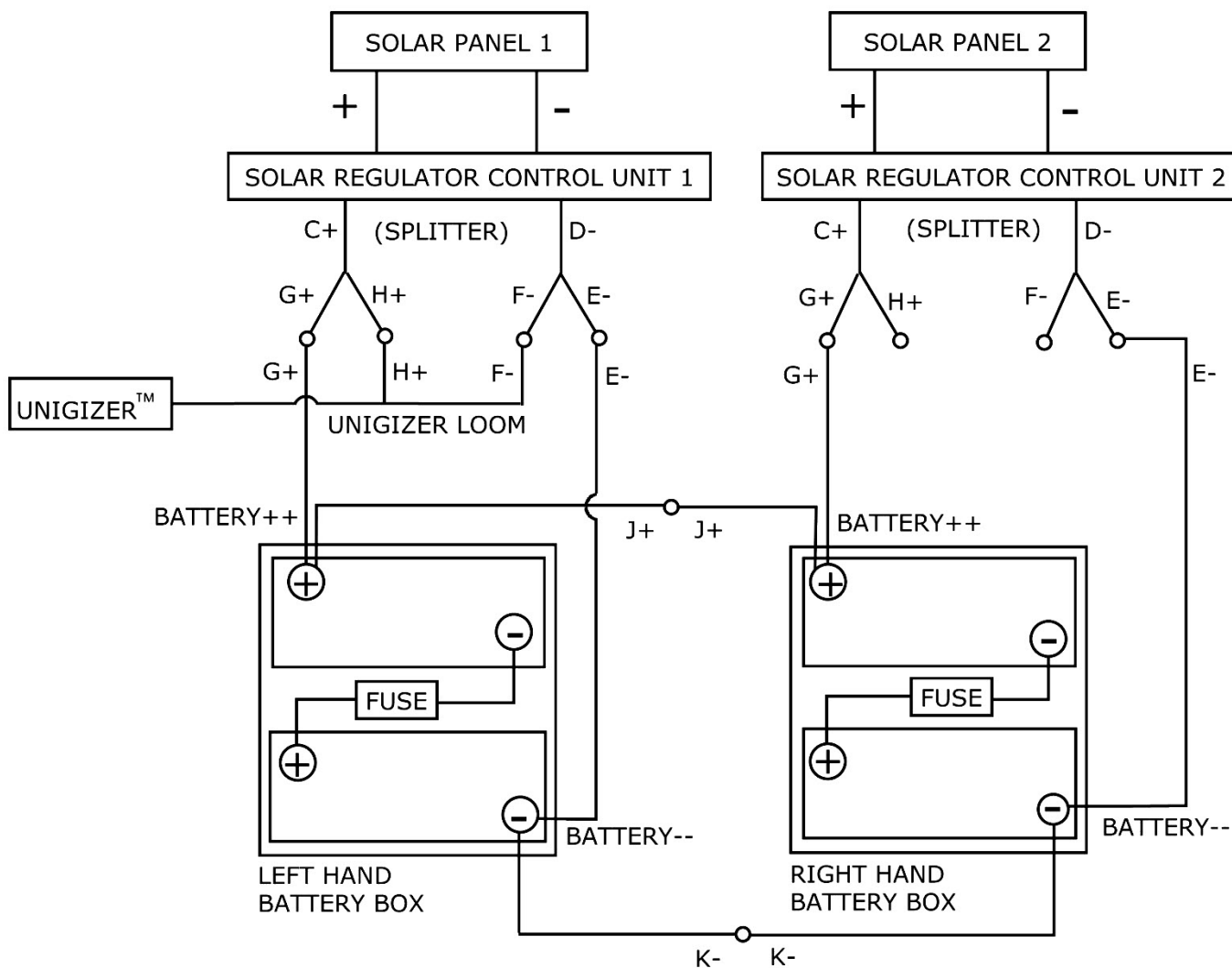







## Components (135 W, 190 W, 270 W)









Note: Some components are available as spare parts, and these are specified by including their part number with their photograph. They are also listed in the *Spare parts list* section (see page 36).

### 135 W components

 <p>1 x 6 J OR 12 J Unigizer™ (example shown). (supplied ONLY with the solar system)</p>  <p><b>880 0009-432</b> 1 x left side panel</p>	 <p><b>880 0009-581</b> 1 x solar panel</p>  <p>Box base: <b>380 0003-261</b> Box lid: <b>380 0003-295</b> 2 x batteries (144 Ah for 6 J Unigizer™ OR 225 Ah for 12 J Unigizer™) and 1 battery box</p>	 <p><b>880 0009-444</b> 1 x mounting box</p>  <p><b>880 0009-434</b> 1 x right side panel</p>	
 <p><b>880 0009-443</b> 2 x post braces (910 mm)</p>	 <p><b>880 0009-442</b> 2 x short frame bars (808 mm)</p>	 <p><b>880 0009-440</b> 2 x long frame bars (1300 mm)</p>	
 <p><b>880 0009-547</b> 1 x Unigizer™ loom</p>	 <p><b>880 0009-548</b> 1 x splitters</p>	 <p>2 x battery lifting handles</p>	
<p>Part of composite component SPARE SOLAR CABLES 135W (<b>880 0009-549</b>)</p>  <p>1 x BATTERY-- cable (6 J Unigizer™ ONLY)</p>  <p>1 x E- cable</p>  <p>1 of these G+ cable configurations (depends on the battery option supplied)</p>  <p>1 x fuse holder cable</p>			

				
<b>480 0000-990</b> 1 x solar regulation control unit	<b>880 0009-438</b> 2 x U-bolts	<b>880 0009-437</b> 2 x angle brackets	<b>380 0003-286</b> 2 x 20 A fuses (4 for 144 Ah battery option)	<b>380 0003-284</b> 2 x 15 A fuses

part of composite item **880 0009-532** (FASTENERS PACK TYPE 190 SOLAR UNIGIZER SOLAR KIT)

					
4 x washers	6 x rubber washers	2 x M12x100 coach screws			
					
8 x M12 flat washers, M12 split washers	4 x M12 nuts	4 x M12x40 bolts	4 x M6x12 Philips screws	4 x M4x8 Philips screws	14 x M8x20 coach bolts, M8 flat washers, M8 nuts

190 W components



1 x 12 J OR 18 J Unigizer™ (example shown).  
(supplied ONLY with the solar system)



**880 0009-423**  
1 x solar panel



**880 0009-444**  
1 x mounting box

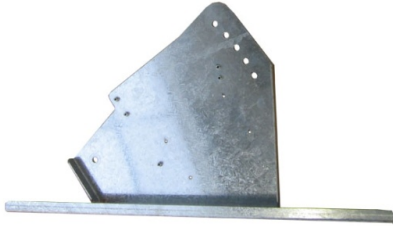

**880 0009-432**  
1 x left side panel



Box base: **380 0003-261**  
Box lid: **380 0003-295**  
2 x batteries (225 Ah for 12 J Unigizer™) and  
1 box OR  
4 x batteries (450 Ah for 18 J Unigizer™) and  
2 boxes

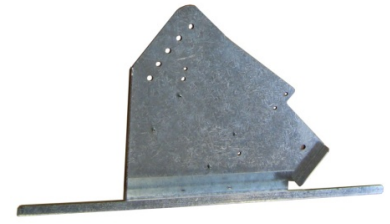

**880 0009-434**  
1 x right side panel



**880 0009-443**  
2 x post braces (910 mm)



**880 0009-442**  
2 x short frame bars (808 mm)



**880 0009-440**  
2 x long frame bars (1300 mm)



**880 0009-547**  
1 x Unigizer™ loom



**880 0009-548**  
1 x splitter



2 x battery lifting handles



1 pair of J+ cables



1 pair of K- cables



2 x E- cables



2 x G+ cables

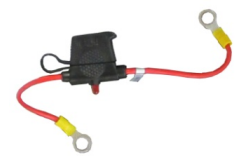

2 x fuse holder cables  
(1 req for 12 J Unigizer™,  
2 req for 18 J Unigizer™)

Part of composite component SPARE SOLAR CABLES 190W 270W (**880 0009-550**)



				
<b>880 0009-938</b> 1 x solar regulator control unit	<b>880 0009-438</b> 2 x U-bolts	<b>880 0009-437</b> 2 x angle brackets	<b>380 0003-286</b> 2 x 20 Amp fuses	<b>380 0003-284</b> 2 x 15 A fuses

part of composite item **880 0009-532** (FASTENERS PACK TYPE 190 SOLAR UNIGIZER SOLAR KIT)

					
4 x washers	6 x rubber washers	2 x M12x100 coach screws			
					
8 x M12 flat washers, M12 split washers	4 x M12 nuts	4 x M12x40 bolts	4 x M6x12 Philips screws	4 x M4x8 Philips screws	14 x M8x20 coach bolts, M8 flat washers, M8 nuts

270 W components



1 x 18 J Unigizer™ (example shown).  
(supplied ONLY with the solar system)



**880 0009-581**  
2 x solar panels



**880 0009-444**  
2 x mounting boxes

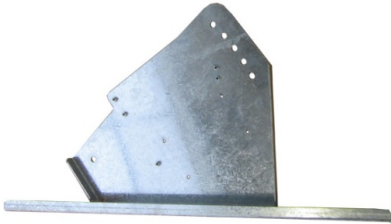

**880 0009-432**  
2 x left side panels



Box base: **380 0003-261**  
Box lid: **380 0003-295**  
4 x batteries (450 Ah for 18 J Unigizer™)  
and 2 boxes

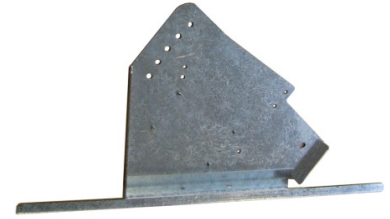

**880 0009-434**  
2 x right side panels



**880 0009-443**  
4 x post braces (910 mm)



**880 0009-442**  
4 x short frame bars (808 mm)



**880 0009-440**  
4 x long frame bars (1300 mm)



**880 0009-547**  
1 x Unigizer™ loom



**880 0009-548**  
2 x splitters



4 x battery lifting handles



1 pair of J+ cables



1 pair of K- cables



2 x E- cables





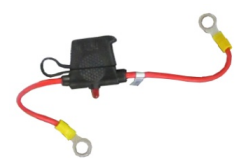

2 x G+ cables











2 x fuse holder cables

Part of composite component **880 0009-550**

				
<b>480 0000-990</b> 2 x solar regulator control units	<b>880 0009-438</b> 4 x U-bolts	<b>880 0009-437</b> 4 x angle brackets	<b>380 0003-286</b> 4 x 20 Amp fuses	<b>380 0003-284</b> 4 x 15 A fuses

part of composite item **880 0009-532** (FASTENERS PACK TYPE 190 SOLAR UNIGIZER SOLAR KIT)

					
8 x washers	12 x rubber washers	4 x M12x100 coach screws			
					
16 x M12 flat washers, M12 split washers	8 x M12 nuts	8 x M12x40 bolts	8 x M6x12 Philips screws	8 x M4x8 Philips screws	28 x M8x20 coach bolts, M8 flat washers, M8 nuts



## Spare parts list

### Individual parts available

Part name	Part number	Qty
BATTERY BOX WHITE PLASTIC 432x324x305mm	<b>380 0003-261</b>	Each
BATTERY LID WHITE PLASTIC 432X324mm	<b>380 0003-295</b>	Each
FUSE BLADE 20A 32V FAST YELLOW AUTOFUSE	<b>380 0003-286</b>	Each
FUSE 15A 250V FAST 6.3x32MM	<b>380 0003-284</b>	Each
BOLT U M12 POST UNIGIZER SOLAR KIT	<b>880 0009-438</b>	Each
BRACKET SIDE LH 815 UNIGIZER SOLAR KIT	<b>880 0009-432</b>	Each
BRACKET SIDE RH 815 UNIGIZER SOLAR KIT	<b>880 0009-434</b>	Each
BRACKET ANGLE UNIGIZER SOLAR KIT	<b>880 0009-437</b>	Each
FRAME BAR 1300 UNIGIZER SOLAR KIT	<b>880 0009-440</b>	Each
FRAME BAR 808 UNIGIZER SOLAR KIT	<b>880 0009-442</b>	Each
PANEL BRACE 910 UNIGIZER SOLAR KIT	<b>880 0009-443</b>	Each
SOLAR REGULATOR CONTROL UNIT FOR 60W TO 135W SOLAR PANEL	<b>480 0000-990</b>	Each
SOLAR PANEL 190W-200W NO REG	<b>880 0009-423</b>	Each
SOLAR PANEL 150W NO REG	<b>880 0009-581</b>	Each
POST MOUNTING BOX UNIGIZER SOLAR KIT	<b>880 0009-444</b>	Each

### Composite parts available

The following components are assembled by Datamars from manufactured items and available as a composite part:

Part name	Part number	Qty
FASTENERS PACK TYPE 190 SOLAR UNIGIZER SOLAR KIT	<b>880 0009-532</b>	Each
SPARE SOLAR CABLES 85W 135W	<b>880 0009-549</b>	Each
SPARE SOLAR CABLES 190W 270W	<b>880 0009-550</b>	Each
SPARE HARNESS SOLAR SPLITTER PAIR	<b>880 0009-548</b>	Each
SPARE HARNESS UNIGIZER TO SOLAR CONN UNIGIZER SOLARCABLE	<b>880 0009-547</b>	Each
SPARE SOLAR REG CONTROL UNIT 200W FOR 190W PANEL	<b>880 0009-938</b>	Each

## Maintenance

### Caring for the solar panels

Check your solar panels once a month to ensure no bird excreta is caked on and covering the panel. A plastic scraping device should be used to clear any build-up. Routinely clean the solar panels every six months with warm, soapy water and a sponge.